

83400405

SPECIFICATION SHEET
WWW.CONEN-SYSTEMS.COM**DISPLAY STAND WITH MOTORIZED HEIGHT ADJUSTMENT SUITABLE FOR THE MICROSOFT SURFACE HUB 2 85" - "VST-MS"
AND DISPLAYS UP TO 110"****PRODUCT**

The mobile display mount was specially developed for the 85" Microsoft Surface Hub and displays up to 110".

As a visual highlight, the columns run flush to the right and left of the display. The VST-MS is characterized by its electrical height adjustment of 60 cm.

The well thought-out design makes it possible to access the internal technology through the removable rear panel and store communication and collaboration equipment there. The system's own cable management is located behind the column. The removable rear panel conceals an integrated shelf for an additional mini PC, for example.

Accessories

Accessories - "VST-MS Side tray, foldable".



Transport handles for mobile display stands



Accessories - "3-way power strip, 5 m cable detachable".

FEATURES

- Max. 100 kg load capacity
- VESA width 400,600,800,1000,1200
- VESA height 200 to 600
- Cable management inside the chassis and behind the column
- On/off switch integrated into the side of the housing
- incl. 4 smooth-running castors, 2 of which are lockable
- Supplied disassembled and packed in cardboard boxes



Display mount



Mobile



Single display

Max. load
100 kg / 220.5 lbsMax. Vesa
1200 x 60007/16/2024
Page 1/2

Item number	83400405	
Vesa horizontal / Vesa vertical	400 mm - 1200 mm / 200 mm - 600 mm	
Load capacity	100 kg	220.5 lbs
Width / Height / Depth	1500 mm / 1180 mm - 1780 mm / 700 mm	59.1" / 46.5" - 70.1" / 27.6"
Packages	Package dimensions WxHxD	Package weight
83400405	1550 x 150 x 700 mm / 61 x 5.9 x 27.6"	60 kg / 132.3 lbs

Dimensions

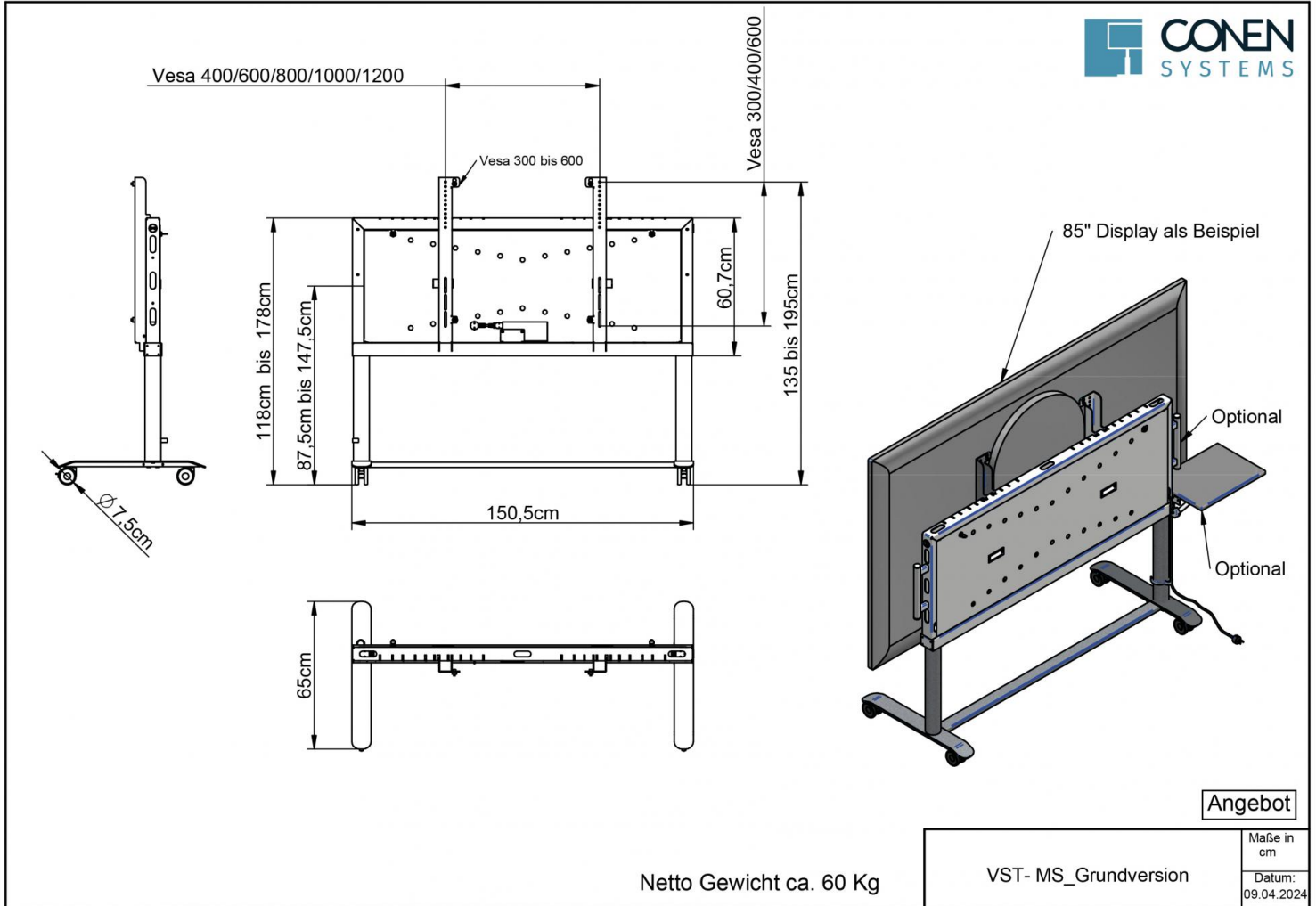

Conen Systems GmbH
 Conenstr. 4
 54497 Morbach-Gonzerath
 Germany

T +49 6533 75-100
 F +49 6533 75-600
 E service@conen-systems.com
www.conen-systems.com

© Copyright by Conen Systems GmbH