

AFSCETAKBR

SPECIFICATION SHEET  
WWW.CONEN-SYSTEMS.COM

## KEYBOARD SHELF FOR LITE SERIES

ADAPTS TO DISPLAY MOUNT

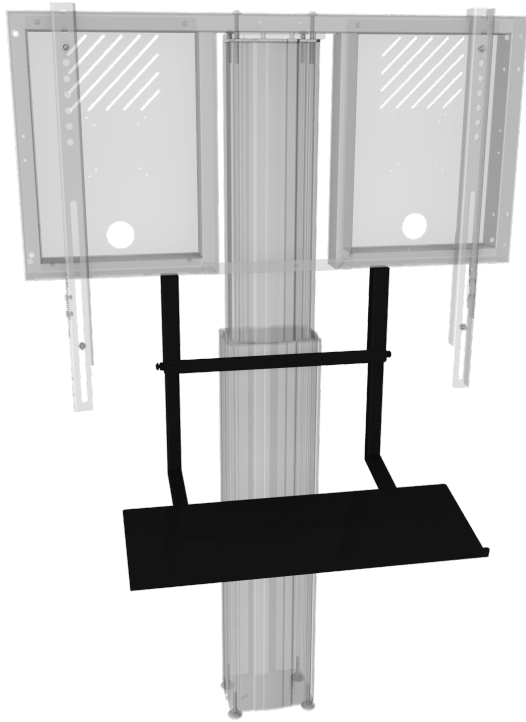

### PRODUCT

Practical keyboard tray for attachment to the display mount. This shelf for keyboards is black and ships including mounting hardware.

### FEATURES

- Keyboard-shelf for mounting to the display mount of LITE series (RLI...)
- Dimension: W/D: 600 x 200 mm
- Powder-coated steel, 2 mm, black (RAL 9005)
- Tube 30 x 30 mm/ 25 x 25 mm
- Includes mounting accessories (2x Allen head lens screws)



Display mount

Max. load  
3 kg / 5.5 lbs

Item number	AFSCETAKBR	
Load capacity	2,5 kg	5.5 lbs
Width / Height / Depth	600 mm / 48 mm / 350 mm	23.6" / 1.9" / 13.8"
Weight	4,4 kg	9.7 lbs
Packages	Package dimensions WxHxD	Package weight
AFSCETAKBR	670 x 90 x 280 mm / 26.4 x 3.5 x 11"	5 kg / 11 lbs

## Dimensions

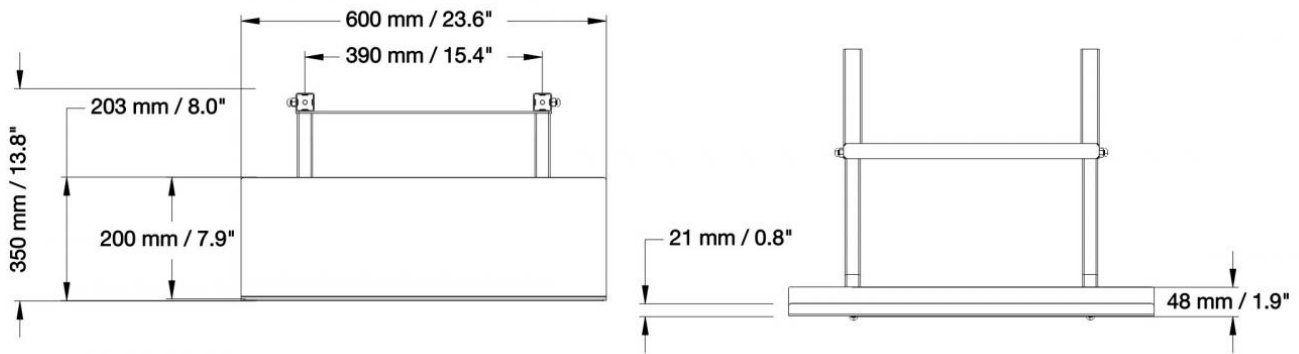

Conen Systems GmbH  
 Conenstr. 4  
 54497 Morbach-Gonzerath  
 Germany

T +49 6533 75-100  
 F +49 6533 75-600  
 E [service@conen-systems.com](mailto:service@conen-systems.com)  
[www.conen-systems.com](http://www.conen-systems.com)

© Copyright by Conen Systems GmbH

08/13/2024  
 Page 2/2