

83400405

SPECIFICATION SHEET  
WWW.CONEN-SYSTEMS.COM

VST-MS - DISPLAY STAND WITH MOTORIZED HEIGHT ADJUSTMENT SUITABLE FOR MICROSOFT SURFACE HUB 2 85"



PRODUCT

The VST-MS mobile display mount was specially developed for the Microsoft Surface Hub 2 85" and offers an elegant and flexible solution for professional applications. With a modern design in which the columns run flush to the right and left of the display, the mount blends seamlessly into any environment. The white columns run flush to the right and left of the display for a clean, elegant appearance. The removable rear panel allows easy access to the internal technology and provides storage space for communication and collaboration equipment. The integrated shelf in the body is ideal for a mini PC or other accessories. The integrated cable management system ensures neat and tidy cable routing. The up and down switch integrated into the side of the housing ensures convenient and continuous adjustment of the display height.

The VST-MS is equipped with 4 castors, 2 of which are lockable, ensuring easy mobility and a secure stand.

Ideal for professional applications in conference rooms, training centers and other environments where large displays and interactive solutions are used for communication and collaboration. The VST-MS mobile display mount offers a versatile, elegant and functional solution that provides both stability and flexibility.

The display mount is supplied disassembled and boxed.

Accessories



Accessories - "VST-MS Side tray, foldable".



Transport handles for mobile display stands



Accessories - "3-way power strip, 5 m cable detachable".

FEATURES

- Electric height adjustment: 60 cm
- Max. load capacity 100 kg
- VESA width 400,600,800,1000,1200
- VESA height 200 to 600
- Cable management inside the chassis and behind the column
- On/off switch integrated into the side of the housing
- incl. 4 smooth-running castors, 2 of which are lockable
- Supplied disassembled and packed in cardboard boxes



Display mount



Mobile



Motorized height adjustable



Single display



Max. load  
100 kg / 220.5 lbs



Max. Vesa  
1200 x 600

Item number	83400405	
Vesa horizontal / Vesa vertical	400 mm - 1200 mm / 200 mm - 600 mm	
Frame for all	86"	
Center to floor distance	875 mm - 1475 mm	34.4" - 58.1"
Load capacity	100 kg	220.5 lbs
Width / Height / Depth	1500 mm / 1180 mm - 1780 mm / 700 mm	59.1" / 46.5" - 70.1" / 27.6"
Packages	Package dimensions WxHxD	Package weight
83400405	1550 x 150 x 700 mm / 61 x 5.9 x 27.6"	60 kg / 132.3 lbs

## Dimensions

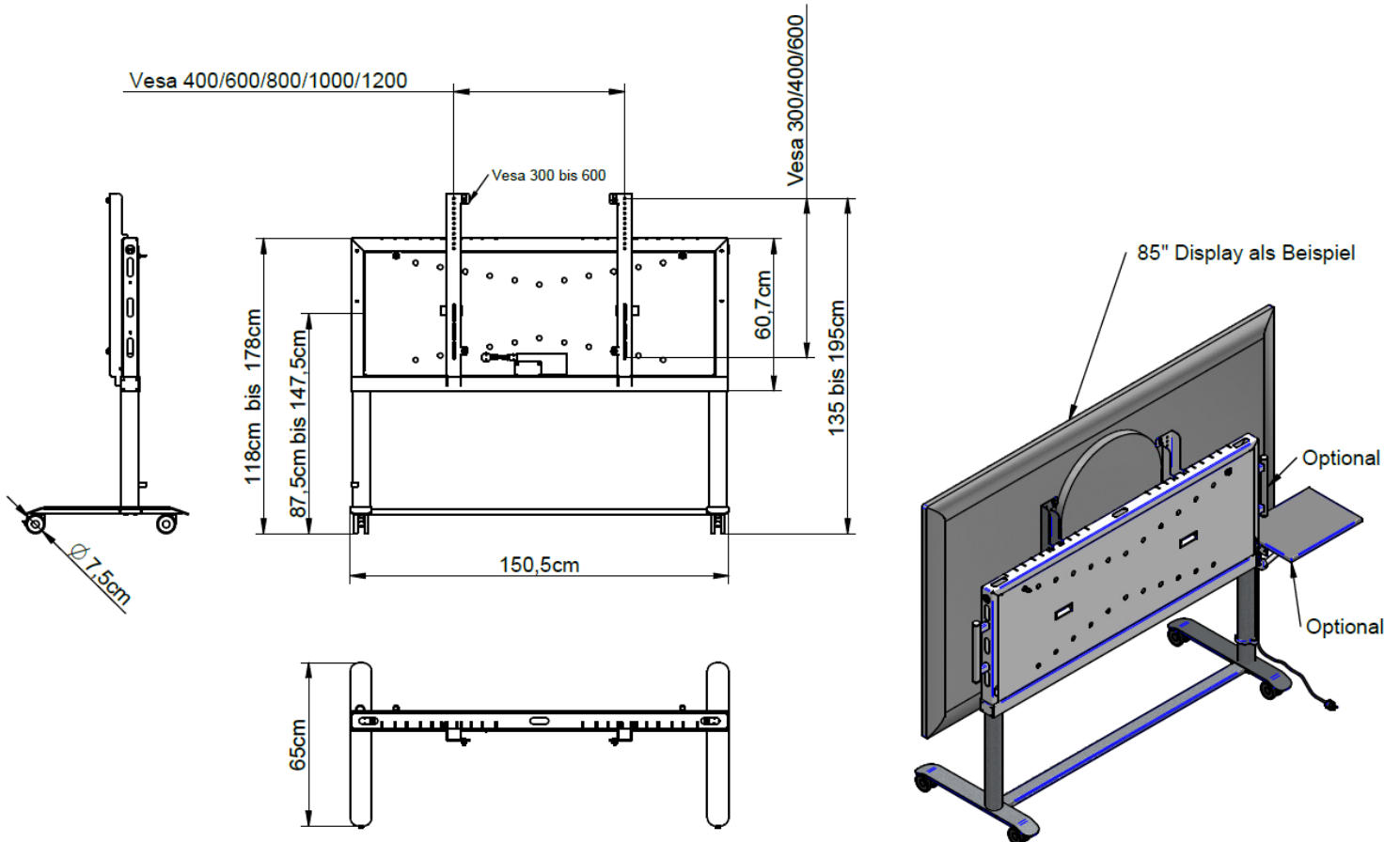

Conen Systems GmbH  
 Conenstr. 4  
 54497 Morbach-Gonzerath  
 Germany

T +49 5251 50012-0  
 E sales@conen-systems.com

[www.conen-systems.com](http://www.conen-systems.com)

© Copyright by Conen Systems GmbH

02/19/2025  
 Page 2/2