

83400301

SPECIFICATION SHEET
WWW.CONEN-SYSTEMS.COM

DISPLAY STAND WITH MOTORIZED HEIGHT ADJUSTMENT - "VST-S"

COLUMN: ANODIZED ALUMINUM WITH V-BASE AND CASTERS



PRODUCT

The electric display stand VST-S is the optimal solution for office and conference rooms. Thanks to its 4 smooth-running castors, 2 of which are lockable, it can be easily moved to another room if required. Ideal for moving almost all display sizes 50 cm in height by motor. An additional height grid in the column attachment allows the height to be varied by a further 20 cm.

The display stand VST-S is available with V- or H-foot as well as with base plate. The column is optionally available in silver anodized or in black. The VST-S is equipped with a universal mount according to VESA standard 100x100 - 800x600. In the column top you will find storage space for smaller technical units. A cover for the storage compartment is included in the scope of delivery.

Due to the motorized lifting column, you can move your display up to max. 130 kg steplessly in height without any problems. Our electric display stands are equipped with an up and off switch. This is attached to the LCD mount with a bracket and is discreetly located directly below your display. This makes handling as easy as possible for you.

To guarantee you a flawless look, the system's own cable management takes place behind the column.

Accessories



Transport handles for mobile display stands

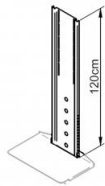

Mounting rail for shelf - 120 cm, for mounting on the



Mounting rail for shelf - 95 cm for mounting on



Telescopic mounting rail - 60 cm for the use of 2 horizontal

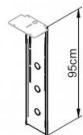

Telescopic mounting rail - 95 cm - HKS modular system



Shelf A - 26 x 17 cm - HKS modular system

FEATURES

- Made in Germany
- For a display up to max. 98"
- Freestanding
- Barrier-free
- Load capacity up to max. 130 kg
- 50 cm motorized movable
- Storage compartment in column top H 50 x W 25 x D 16 (D 16 cm at the widest point!)



Display mount



Mobile



Motorized height adjustable



Single display



Multi display



Max. load
130 kg / 286.6 lbs



Max. Vesa
800 x 600

Item number	83400301	
Vesa horizontal / Vesa vertical	100 mm - 800 mm / 100 mm - 600 mm	
Frame for all	98" max.	
Load capacity	130 kg	286.6 lbs
Width / Height / Depth	1220 mm / 1550 mm - 2050 mm / 650 mm	48" / 61" - 80.7" / 25.6"
Weight	62 kg	136.7 lbs

Conen Systems GmbH
Conenstr. 4
54497 Morbach-Gonzerath
Germany

T +49 6533 75-100
F +49 6533 75-600
E service@conen-systems.com
www.conen-systems.com

© Copyright by Conen Systems GmbH