

FSH-SMLI

SPECIFICATION SHEET
WWW.CONEN-SYSTEMS.COM

FRONT SHELF FOR LIGHT SYSTEM

CONNECTS TO CENTRAL ALUMINUM COLUMN

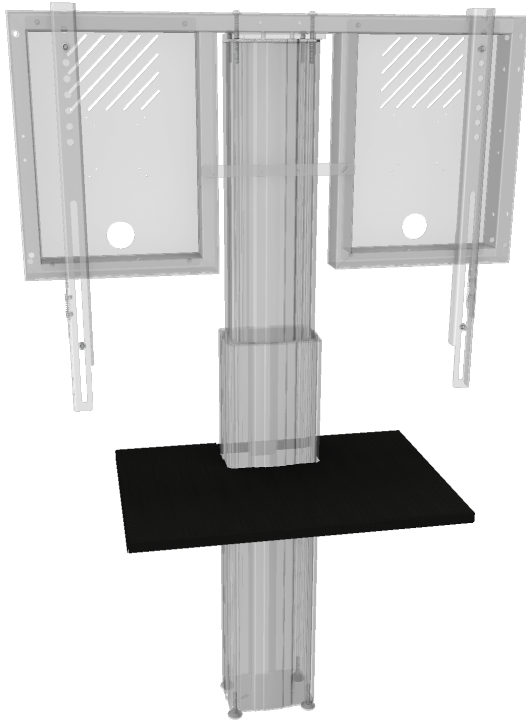

PRODUCT

Sturdy front shelf can be connected to the central column.

FEATURES

- Compatible with LIGHT (RLI... and CCELWAF) series
- Front shelf connects to the central column
- Steel 2mm
- Powder coated in black, RAL 9005
- Assembly material included
- Carries up to 10 kg



Display mount

Max. load
10 kg / 22 lbs08/13/2024
Page 1/2

Item number	FSH-SMLI	
Load capacity	10 kg	22 lbs
Width / Height / Depth	600 mm / 21 mm / 400 mm	23.6" / 0.8" / 15.7"
Weight	3,8 kg	8.4 lbs
Packages	Package dimensions WxHxD	Package weight
FSH-SMLI	630 x 60 x 430 mm / 24.8 x 2.4 x 16.9"	4,3 kg / 9.5 lbs

Dimensions

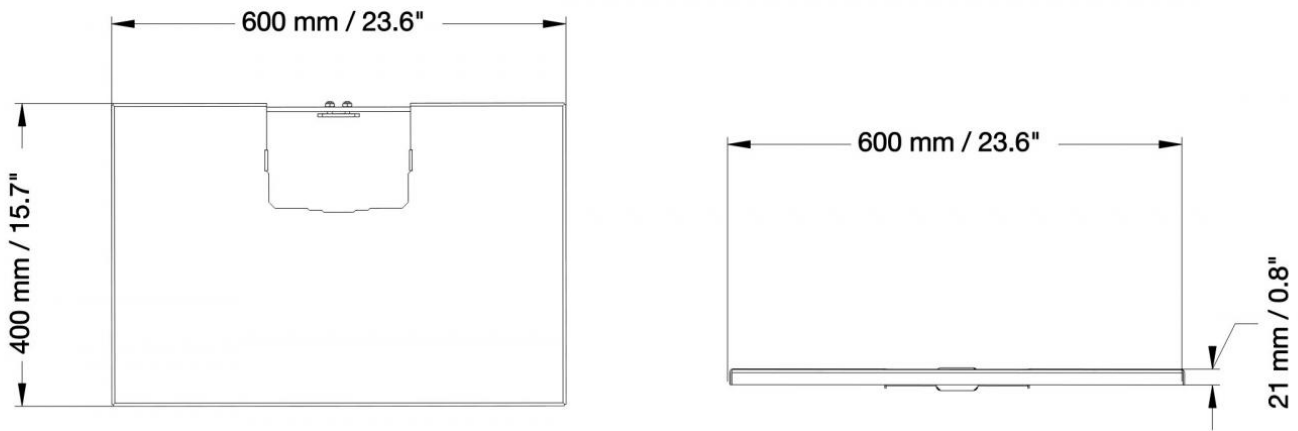

Conen Systems GmbH
 Conenstr. 4
 54497 Morbach-Gonzerath
 Germany

T +49 6533 75-100
 F +49 6533 75-600
 E service@conen-systems.com
www.conen-systems.com

© Copyright by Conen Systems GmbH

08/13/2024
 Page 2/2