

REM-FOOT

SPECIFICATION SHEET
WWW.CONEN-SYSTEMS.COM**FOOT REMOTE CONTROL WITH 2 SHIFTERS IN GREY**

TO OPERATE THE ELECTRICAL HEIGHT ADJUSTMENT OF THE PYLON COLUMN

PRODUCT

All electrically height-adjustable and tiltable display mounts are supplied with a cable control panel. This footswitch extends this functionality. The switch is equipped with 2 buttons and controls the electrical height adjustment of the display mount. The column can be driven up and down.

The operability by foot switch can not be retrofitted!

FEATURES

- Simple and quick control by foot
- Colour: grey



Display mount

Item number	REM-FOOT	
Width / Height / Depth	195 mm / 37 mm / 135 mm	7.7" / 1.4" / 5.3"

Dimensions

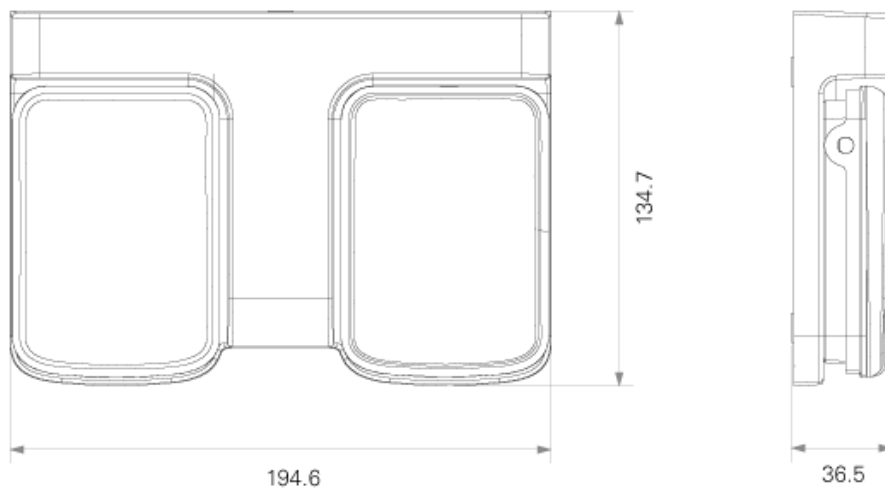

Conen Systems GmbH
Conenstr. 4
54497 Morbach-Gonzerath
Germany

T +49 5251 50012-0
E sales@conen-systems.com

www.conen-systems.com

© Copyright by Conen Systems GmbH

10/30/2024
Page 2/2