

## GRIFF-SCETA

SPECIFICATION SHEET  
WWW.CONEN-SYSTEMS.COM

## TWO LARGE AND STURDY HANDLES INCLUDING LAPTOP SHELF

CONNECT TO THE DISPLAY MOUNT

PRODUCT

Large handles on each side of the display increase mobility and help protect the display in transport. A laptop shelf is included and can be mounted on the handles.

Accessories

Laptop shelf



Laptop shelf

FEATURES

- Powder coated in black
- Set of 2 handles 1 laptop shelf
- Assembly material for mounting of the handles to the display mount is included
- Increase of mobility and protection of display in transport
- Height 85 cm



Display mount

Max. load  
10 kg / 22 lbs

Item number	GRIFF-SCETA	
Frame for all	55" - 86"	
Load capacity	10 kg	22 lbs
Width / Height / Depth	490 mm / 700 mm / 236 mm	19.3" / 27.6" / 9.3"
Weight	12,1 kg	26.7 lbs
Packages	Package dimensions WxHxD	Package weight
GRIFF-SCETA	730 x 240 x 470 mm / 28.7 x 9.4 x 18.5"	13,8 kg / 30.4 lbs

## Dimensions

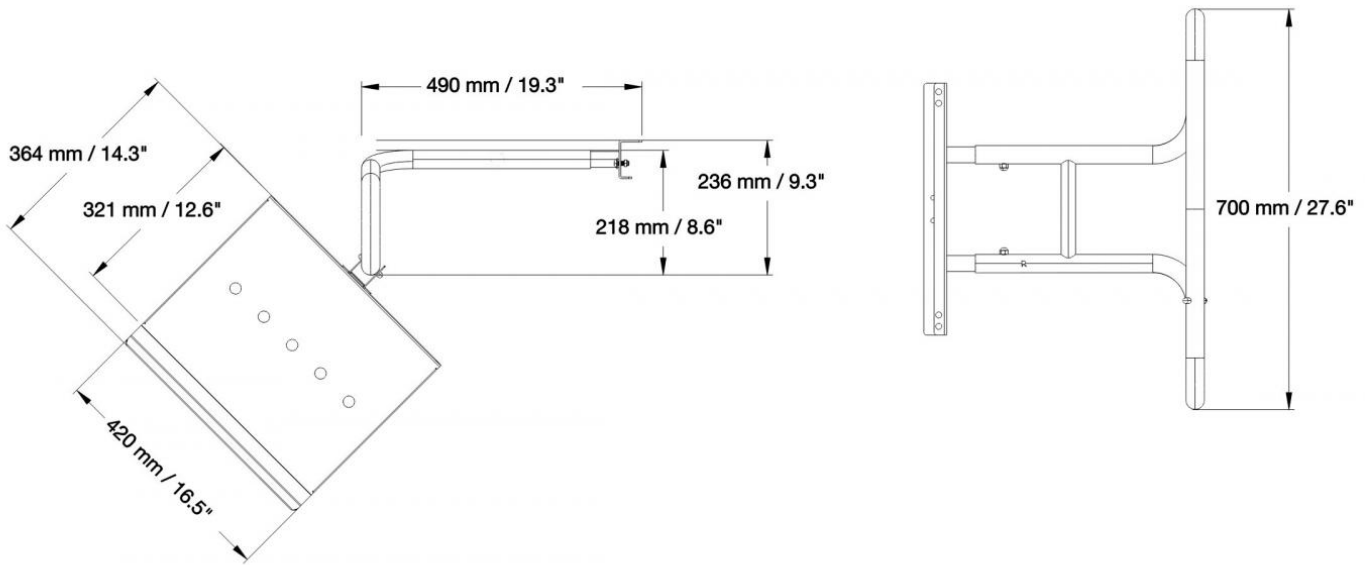

Conen Systems GmbH  
 Conenstr. 4  
 54497 Morbach-Gonzerath  
 Germany

T +49 6533 75-100  
 F +49 6533 75-600  
 E [service@conen-systems.com](mailto:service@conen-systems.com)  
[www.conen-systems.com](http://www.conen-systems.com)

© Copyright by Conen Systems GmbH

08/13/2024  
 Page 2/2